



EXTRACTOR-INYECTOR TUBO AXIAL DE ALTA EFICIENCIA EN ACOPLAMIENTO DIRECTO ALABES AJUSTABLES



¡COTIZA AHORA!



55- 6840-6103

www.grupodiarventilacion.com

DESCRIPCIÓN

La serie Extractores - Inyectores tubo axiales en acoplamiento directo ha sido especialmente diseñada para aplicaciones industriales en conductos disponibles en 36 modelos distintos con 4 diámetros de hélice de alabes en ángulo variable estandarizada de 24", 30", 36" y 42" brindando caudales desde 9,000 hasta 52,000 m³/hr.

CARACTERÍSTICAS PRINCIPALES:

- Carcaza tubular y bridas fabricadas en acero al carbón con acabado en pintura poliéster en polvo horneada.
- Hélice de aluminio inyectado o polipropileno reforzado con fibra de vidrio de 7 alabes en ángulo variable balanceada dinámicamente, anti-chispa, altamente resistente a la corrosión.
- Accionado por acoplamiento directo a los motores eléctricos trifásicos de eficiencia premium en 4, 6 y polos, diseñados bajo las especificaciones NEMA.

APLICACIONES:



**Procesos
Industriales**



**Torres de
enfriamiento**



**Extracción de
humo**



Tuneles

ESPECIFICACIONES TÉCNICAS

MODELO (MODEL)	CAUDAL @ DESCARGA LIBRE		AMPERAJE(A) @ 60HZ.		POTENCIA (HP)	RPM	NIVEL SONORO db (A)*	PESO APROX.	
	CFM	M ³ /HR	3 FASES					Lb.	Kg.
			220V	440V					
XDP/A-4-24/20°	6,350	10,789	5.2	2.6	1.5	1760	64	64	29
XDP/A-4-24/25°	7,970	13,541	6.6	3.3	2.0	1760	69	66	30
XDP/A-4-24/32.5°	10,500	17,840	9.8	4.9	3.0	1760	75	101	46
XDP/A-4-24/40°	12,800	21,747	15.0	7.5	5.0	1760	79	106	48
XDP/A-6324/25°	5,250	8,920	2.4	1.2	1/2	1160	60	46	21
XDP/A-6-24/30°	6,360	10,806	2.8	1.4	3/4	1160	64	53	24
XDP/A-6-24/35°	7,500	12,743	3.8	1.9	1.0	1160	67	57	26
XDP/A-6-24/40°	8,440	14,340	4.8	2.4	1.5	1160	70	90	41
XDP/A-6-24/45°	9,200	15,631	6.2	3.1	2.0	1160	72	92	42
XDP/A-4-30/20°	10,500	17,840	6.6	3.3	2	1760	73	90	41
XDP/A-4-30/25°	13,600	23,106	9.8	4.9	3	1760	78	126	57
XDP/A-4-30/30°	16,700	28,373	15.0	7.5	5	1760	83	130	59
XDP/A-4-30/32.5	18,400	31,262	15.0	7.5	5	1760	85	130	59
XDP/A-6-30/20°	6,900	11,723	2.8	1.4	3/4	1160	64	77	35
XDP/A-6-30/25°	8,950	15,206	3.8	1.9	1	1160	69	82	37
XDP/A-6-30/32.5°	12,100	20,558	6.2	23.10	2	1160	76	117	53
XDP/A-6-30/40°	15,200	25,825	8.4	24.27	3	1160	81	148	67

MODELO (MODEL)	CAUDAL @ DESCARGA LIBRE		AMPERAJE (A)@ 60HZ.		POTENCIA (HP)	RPM	NIVEL SONORO db (A)*	PESO APROX.	
	CFM	M ³ /HR	3 FASES					Lb.	Kg.
			220V	440V					
XDP/A-4-36/25°	18,300	31,092	15.0	7.5	5.0	1760	73	176	80
XDP/A-4-36/30°	23,600	40,096	23.0	11.5	7.5	1760	78	189	86
XDP/A-6-36/25°	12,100	20,558	4.8	2.4	1.5	1160	64	125	57
XDP/A-6-36/30°	15,500	26,335	6.2	3.1	2.0	1160	69	145	66
XDP/A-6-36/35°	19,300	32,791	8.4	4.2	3.0	1160	74	163	74
XDP/A-6-36/40°	22,600	38,397	14.2	7.1	5.0	1160	77	216	98
XDP/A-8-36/30°	11,500	19,539	4.0	2.0	1.0	860	63	147	67
XDP/A-8-36/35°	14,300	24,296	5.4	2.7	1.5	860	67	163	74
XDP/A-8-36/40°	16,800	28,543	7.0	3.5	2.0	860	71	194	88
XDP/A-8-36/45°	19,500	33,131	9.8	4.9	3.0	860	74	205	93
XDP/A-4-42/25°	25,100	42,645	23.0	11.5	7.5	1760	80	207	94
XDP/A-6-42/30°	22,000	37,378	8.4	4.2	3	1160	77	181	82
XDP/A-6-42/32.5°	25,000	42,475	14.2	7.1	5	1160	80	234	106
XDP/A-6-42/35°	28,100	47,742	14.2	7.1	5	1160	82	234	106
XDP/A-6-42/37.5°	30,500	51,820	20.0	10.0	7.5	1160	84	331	150
XDP/A-8-42/25°	12,300	20,898	4.0	2.0	1	860	65	165	75
XDP/A-8-42/30°	16,300	27,694	5.4	2.7	1.5	860	71	181	82
XDP/A-8-42/32.5°	18,600	31,601	7.0	3.5	2	860	73	212	96
XDP/A-8-42/35°	20,800	35,339	9.8	4.9	3	860	76	223	101

DIMENSIONES

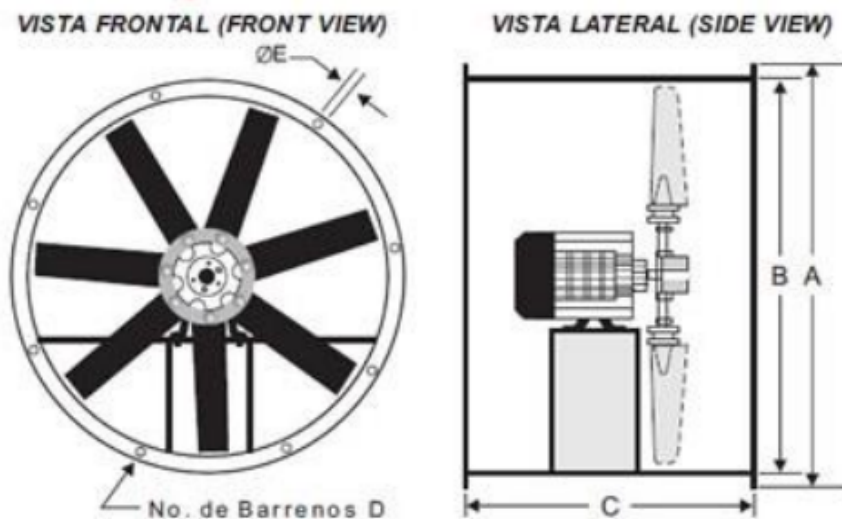

Dimensiones Generales (Dimensions)

MODELO (MODEL)	Pulgadas (Inches)				
	A	B	C	D	ØE
XDP/A-24	28	25	19	8	1/2
XDP/A-30	35	31	19	8	1/2
XDP/A-36	41	37	24	8	1/2
XDP/A-42	47	43	24	8	1/2

SÍGUENOS
@grupodiarventilación

